



### EPA Certified / Stationary Emergency

OUTPUT POWER OPTIONS					STANDBY RATING		sKVA
Make	Voltage	Alternator	Phase	Hertz	kW/kVA	Amps	30% Voltage Dip
Stamford	600	S0L2-M41-17	3	60	20/25	24	70
	277/480	S0L2-M41-311	3	60	20/25	30	39
	120/208	S0L2-M41-311	3	60	20/25	69	26
	120/240	S0L2-M41-311	3	60	20/25	60	26
	120/240	S0L2-M41-311	1	60	15/15	63	21
	120/240	S0L2-M41-706	1	60	20/20	83	36
Marathon	600	282PSL5249	3	60	20/25	24	79
	277/480	282PSL1705	3	60	20/25	30	72
	120/208	282PSL1705	3	60	20/25	69	54
	120/240	282PSL1705	3	60	20/25	60	54
	120/240	282PSL1705	1	60	17/17	71	25
	120/240	282PSL1716	1	60	20/20	83	42



**Engine Data**

Manufacturer	Perkins
Model	404D-22G
Aspiration	Naturally Aspirated
EPA Tier	4i
Charge Air Cooling System	Air-to-Air
Arrangement	Vertical Inline, 4-Cycle
Firing Order	1-3-4-2
Displacement: L (in. <sup>3</sup> )	2.22 (135.23)
Bore: mm (in.)	84.00 (3.31)
Stroke: mm (in.)	100.00 (3.94)
Compression Ratio	23.3:1
BMEP: psi (kPa)	106.02 (731.00)
Net Horsepower	32.03
Rated RPM	1800
Governor	Mechanical
Speed Regulation	±0.5%

**Engine Liquid Capacity**

Oil System: qt. (L)	11.20 (10.60)
Cooling Capacity: gal (L)	1.85 (7.00)

**Engine Electrical**

Electric Volts: DC	12
Cold Cranking Amps	450
Battery(s) Required	1

**Fuel System**

Fuel Injection Type	Indirect
Fuel Pump Rate: gal/hr (L/hr)	0.28 (1.05)
Pump Pressure: in. H <sub>2</sub> O (kPa)	50.00 (10.00)
Max Suction Head: ft (m)	2.63 (0.80)
Max Pressure Head: ft (m)	9.84 (3.00)
Recommended Fuel	Ultra Low Sulfur Diesel

**Air Requirements**

Air Filter(s) Type	Dry
Combustion Air Flow: CFM (m <sup>3</sup> /min)	61.45 (1.74)
Maximum Air Intake Restriction	
Clean: in. H <sub>2</sub> O (kPa)	12.04 (3.00)
Dirty: in. H <sub>2</sub> O (kPa)	25.69 (6.40)
Radiator Air Flow: CFM (m <sup>3</sup> /min)	1652.7 (46.8)

**Exhaust System**

Gas Temperature: °F (°C)	950.0 (510.0)
Gas Flow: CFM (m <sup>3</sup> /min)	168.10 (4.76)
Max Back Pressure: in. H <sub>2</sub> O (kPa)	40.94 (10.20)
Exhaust Outlet Size: in. (mm)	1.65 (42.00)

**Sound Level**

Open Unit Without Exhaust: dBA 3.2 ft (1M)	79
--	----

**Filters and Quantity**

Air Cleaner Quantity	1
Oil Filter(s) Quantity	1
Fuel Filter(s) Quantity	2

**Fuel Consumption**

At 100% of Power Rating: gal/hr (L/hr)	1.64 (6.20)
At 75% of Power Rating: gal/hr (L/hr)	1.27 (4.80)
At 50% of Power Rating: gal/hr (L/hr)	0.93 (3.50)
At 25% of Power Rating: gal/hr (L/hr)	N/A

**Cooling System**

Rejection to Radiation: kW (BTUM)	4.60 (261.60)
Rejection to Fluids: kW (BTUM)	22.2 (1262.5)
Coolant Flow: gal/min (L/min)	14.85 (56.20)

**GENERAL GUIDELINES FOR DERATION:** Altitude: Derate 0.5% per 100m (328 ft.) Elevation above 1000m (3279 ft.) Temperature: Derate 1.0% per 10°C (18°F) temperature above 25°C (77°F)

**RATINGS:** All three-phase units are rated at 0.8 power factor. All single-phase units are rated at 1.0 power factor.

**125° RATINGS:** 125° apply to installations served by a reliable utility source. The standby rating is applicable to varying loads for the duration of a power outage. There is no overload capability for this rating. Ratings are in accordance with ISO-3046/1, BS 5514, AS 2789, and DIN 6271. For limited running time and base load ratings consult the factory. The generator set manufacturer reserves the right to change the design or specifications without notice and without any obligation or liability whatsoever.

## Alternator Data

Manufacturer	Stamford
Type	Self-Excited
Insulation Class	NEMA H
Temperature Rise	125°C Standby
Hertz	60
RPM	1800
Amortisseur Windings	Full
CFM Cooling Required	340
Voltage Regulator	VITA 01
Sensing	Single Phase
Voltage Regulation	0.5%

## Features

- BS EN 60034, BS5000, VDE 0530, NEMA MG1-32, IEC34, CSA C22.2-100, and AS1359 compliant
- IP23 enclosure
- Dynamically balanced to exceed BS6861:Part 1 Grade 2.5 vibration standard
- Quality assurance to BS EN ISO 9001
- Self-ventilated and drip proof construction
- Two-thirds pitch stator and skewed rotor
- Heavy duty bearings
- Fully guarded
- Overexcitation protection
- Under frequency protection
- Digital voltage regulator
- Single-phase sensing

## Alternator Data

Manufacturer	Marathon
Type	Self-Excited
Insulation Class	NEMA N
Temperature Rise	125°C Standby
Hertz	60
RPM	1800
Amortisseur Windings	Full
CFM Cooling Required	250
Voltage Regulator	SE350
Sensing	Single Phase
Voltage Regulation	1.0%

## Features

- NEMA MG1-32, BS5000, and IEC 34-1 compliant; CE & CSA Certified and UL Listed
- Self-ventilated and drip proof construction
- Two-thirds pitch stator and skewed rotor
- Wet wound, epoxied field windings
- Designed to withstand overspeeds of up to 125%
- Analog voltage regulator
- Easy access front-panel adjustments
- Under-frequency, stability and voltage adjustments
- Internal provisions for automatic voltage build up from generator residual voltage
- Electromagnetic interference filter

## Control Panels



### DeepSea 7310 MKII

Simultaneous Use of RS232 & RS485  
 Modbus RTU Support  
 Fully Configurable Using USB, RS232 & RS485  
 IP65 Rating  
 6 Programmable Inputs & 8 Outputs  
 UL & cUL Listed and CE Certified



### Basler DGC2020

SAE J1939 Engine ECU Communications  
 4 Programmable Inputs & 10 Outputs  
 Modbus Communications With RS485  
 UL Recognized, CSA & CE Certified  
 IP 54 Front Panel Rating  
 NFPA 110 Level 1 Compatible  
 Manual Override Keyswitch  
 DGC2020HD Variant Available



### Taylor Analog

Automatic CANBUS Engine Control  
 Gauge Zeroing on Shutdown  
 Auto-Off-Manual Control Switch  
 Oil Pressure, Water Temperature, Battery Voltage and RPM Gauges  
 AC Voltage, Frequency, Percent of Load, and Run-Time Metering  
 LED Status Lights

**Standard Features:**

**Warranty**

2 Year Standard
5 Year Comprehensive

- |                                    |                        |
|------------------------------------|------------------------|
| Heavy Duty Steel Base              | Battery Charger        |
| Vibration Isolators                | Block Heater           |
| Oil Drain Valve with Extension     | Factory Powder Coating |
| Coolant Drain Kit                  | Factory Load Test      |
| High Ambient Unit Mounted Radiator | Owner's Manual         |

**Controller Options**

DGC2020HD Controller
Fiber Optic Ethernet (DGC2020HD)
RS-232 Port & Generator Protection (DGC2020)
Flush or Surface Mount Remote Annunciator
Remote Mount Break Glass E-Stop Switch

**Miscellaneous Options:**

- |                        |                         |
|------------------------|-------------------------|
| Generator Strip Heater | Pad Type Battery Heater |
| Spring Isolators       | Battery Heater Blanket  |
| Line Circuit Breaker   | Oil Pan Heater          |

**Open Unit**

**Options:**

- Radiator Duct Flange
- Flex Exhaust
- Critical Silencer
- Sub-Base Fuel Tank

Overall Size: 60"L x 32"W x 51"H  
Approximate Weight: 1,500 lbs.

*Note: Dimensions and weights reflect standard open unit with no options and are subject to change.*

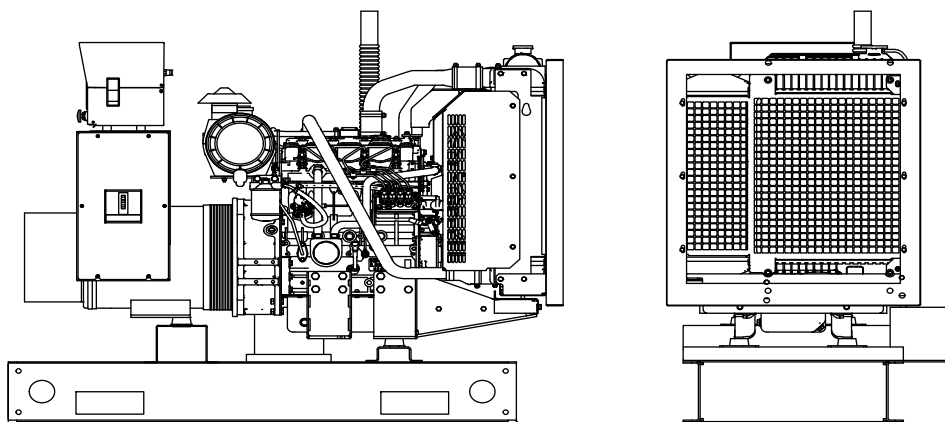

**Standard Enclosed Unit**

**Options:**

- Sound Attenuated Enclosure
- Load Center, Lights & GFI Receptacle
- Sub-Base Fuel Tank

Overall Size: 78"L x 46"W x 46"H  
Approximate Weight: 1,700 lbs.

*Note: Dimensions and weights reflect standard enclosed unit with no options and are subject to change.*

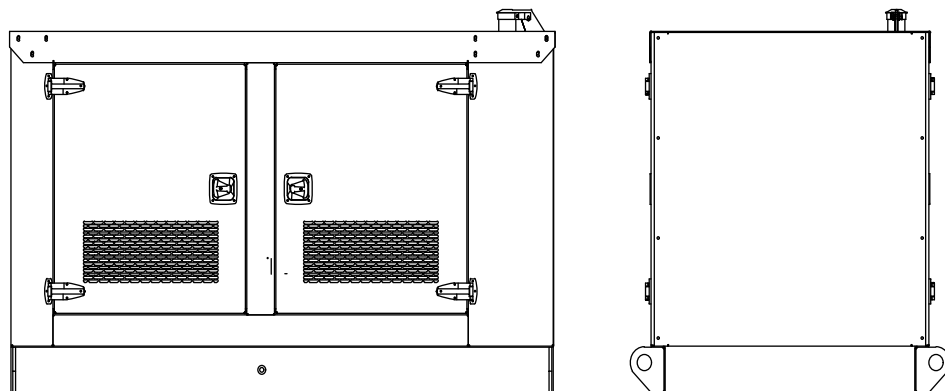

**Note: The above drawings are provided for reference only and should not be used for planning installation. Contact your local distributor for more information.**